

SPECIFICATION

Contact Rating: 10A/250VAC (C-UL&UL, VDE, 3C)
 Insulation Resistance: 100MΩ (min) 500VDC
 Dielectric Strength: 2000VAC/1 minute

SERIES NUMBER: SC04-1BWW-331



PART NUMBERING SYSTEM

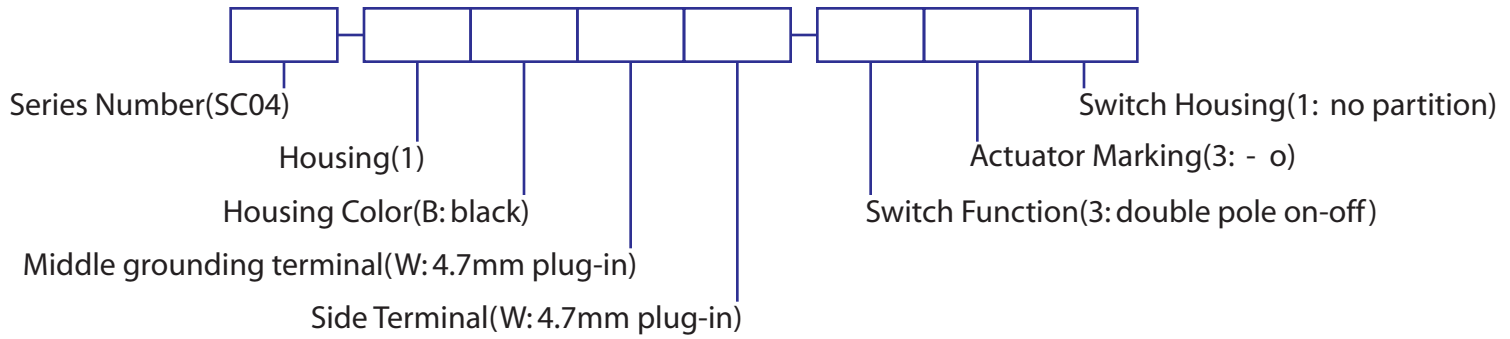

DIMENSIONS(mm)

