

SPECIFICATION

SERIES NUMBER: OR-2

Contact Rating: 10A/125VAC 6A/250VAC(UL, CSA)
 6A/250VAC 1E4
 6A/100A 250VAC~μ 6E3(N,S,D,FI)
 Contact Resistance: 50mΩ (max) at initial
 Insulation Resistance: 100MΩ (min) 500VDC
 Dielectric Strength: 2500VAC/1 minute
 Electrical Life: 10,000 cycles
 Operation Force: 800+/-200g(SP), 1500+/-200(DP)



PART NUMBERING SYSTEM

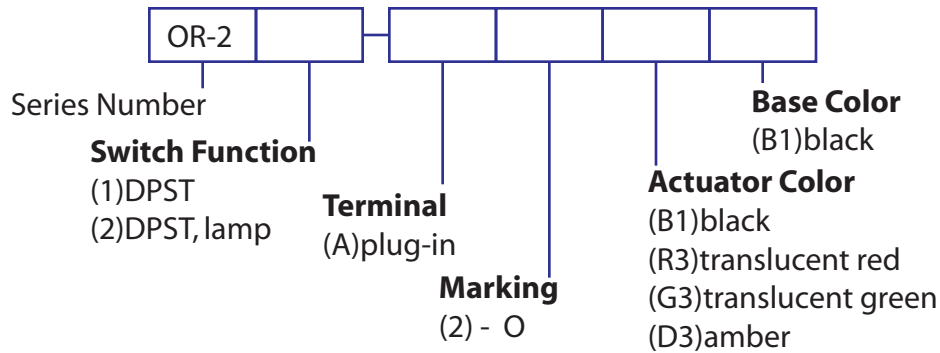

DIMENSIONS(mm)

